

# WRAP AROUND HINGE (INSET DOOR)

26898-906

26898 - Polished Brass  
29606 - Antique Brass

## FEATURES:

- for 3/4" thick inset doors. (flush
- 180° door opening
- made of .053" steel
- has a removable pin for left or right mounting
- has extra strength from wrap around feature
- reversible
- supplied with 5/8" x #5 screws

## APPLICATIONS:

A hinge used for hanging 3/4" thick inset doors and is especially good for use in plywood cabinets.

## SPECIFICATIONS:

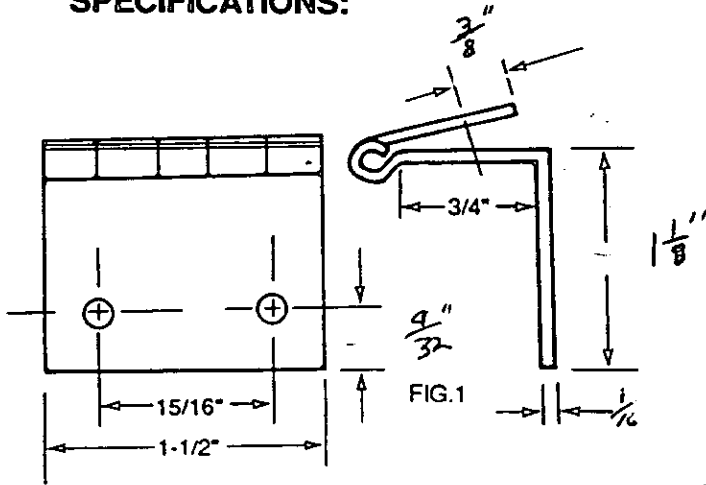

## INSTALLATION:

(3/4" thick door hung on cabinet with face frame)

1. Locate hinges approximately 2" x 3" from door corners and place marks on door edge (1-1/2" width). Use a square and draw lines across door edge for recess (gain).
2. Cut hinge recess in door edge, approximately 1/8" (thickness across both leaves in closed position measured at barrel).
3. Place hinge in recess (gain) and mark 3 screw hole centers - one on door edge and 2 on inner door face.
4. Drill pilot holes and attach hinge to door with supplied screws. Pull pin to release frame leaf.
5. Place door into opening and shim bottom and sides for clearance. Mark location of both hinges on face frame edge. Remove door from opening.
6. Use combination square set as a marking gauge for 3/8" and run center (vertical) line on face frame edge. (See Fig. 2)
7. Place hinge leaf to face frame edge, align with location marks, position 3/8" center line in middle of screw holes and then mark screw hole location on face frame edge.
8. Drill pilot holes in face frame and attach hinge leaf to face frame.
9. Place door back in cabinet opening, align sections of barrel and insert pin into barrel.

