

Drill Press Table Mounting Instructions

View from bottom of
Drill Press Table

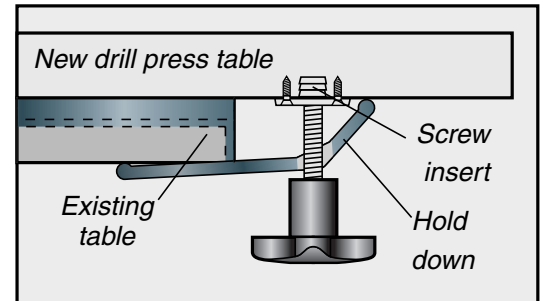
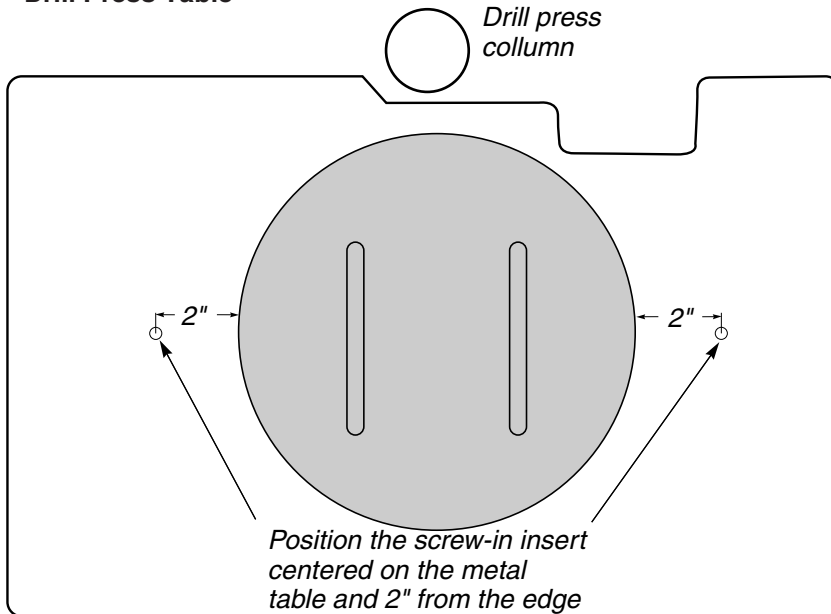

1. Position Rockler table on existing metal drill press table, centered side-to-side and 1/4" from the drill press column.
2. Locate the position of the screw-in inserts on the underside of the Rockler table 2" from the edge of the metal table, and centered front-to-back on the metal drill press table.
3. On the bottom side of the Rockler table, drill two 1/2" x 5/8" deep holes and install the screw-in inserts using the #5 x 5/8" screws provided.
4. Thread the two 5/16"x3" threaded studs into the inserts, slide on the hold down clamps, and position as shown. Clamp the Rockler table to the metal drill press table with the 2" star knob.

Packing list

1. 28½" x 21" melamine coated MDF surface
2. 1/2" thick table insert 4" x 8"
3. Mounting Hardware consisting of:
 - 2- Hold down clamps
 - 2- 5/16" x 3" studs
 - 2- 2" knobs
 - 2- washers
 - 6- #5 x 5/8" screws
 - 2- 5/16"x 18 screw-in insert

Drill Press Table Fence Assembly

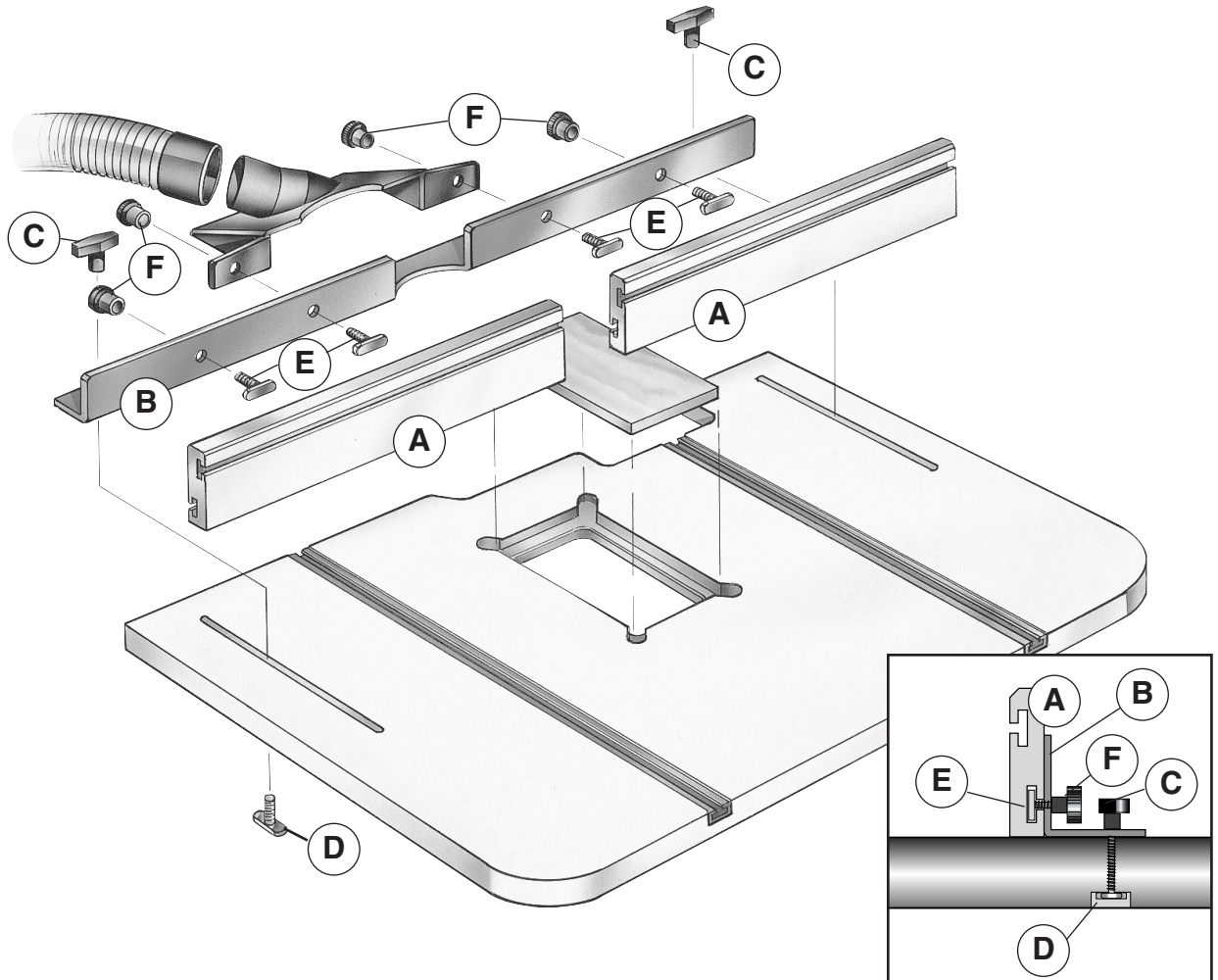

Packing list

- A ...2ea. 14¼" Melamine face fences
- B ...1ea. 28½" Aluminum fence
- C ...2ea. 2" T-knobs
- D ...2ea. 5/16" x 1½" T-bolts
- E ...4ea. 5/16" x 1" T-bolts
- F ...4ea. 1" Round knobs

Dust Port sold separately (# 23195)