

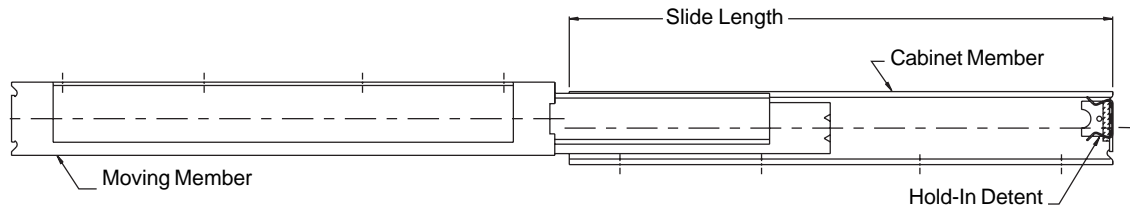

**APPLICATIONS:** Pull-out storage shelves, kitchen pull-out pantries, and entertainment centers.

Note: Rockler pantry slide kits 91968 and 91976 each consist of a pair of Accuride 301-2590 slides combined with a single Accuride 3832 Series slide. This datasheet information is intended only as a supplement to the instructions provided with the kits.

**91968, 91976**  
**MODEL 301-2590**  
 Undermount Shelf Slide  
 Non-Disconnect  
 Over Travel  
 130 lb. [59 kg.] Capacity

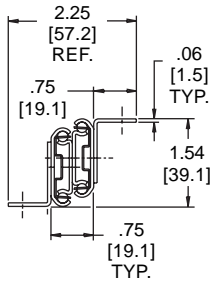
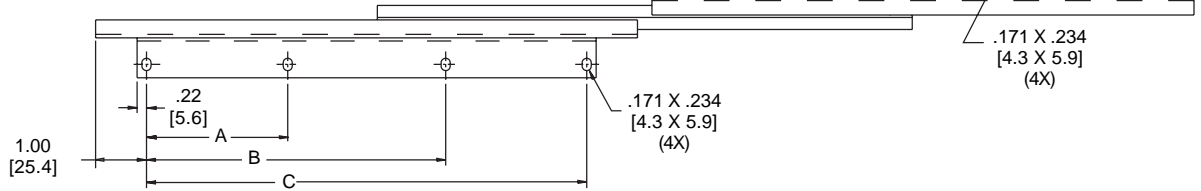
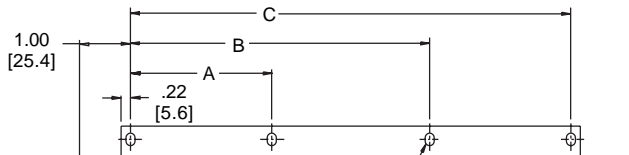
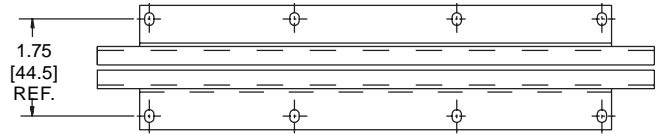
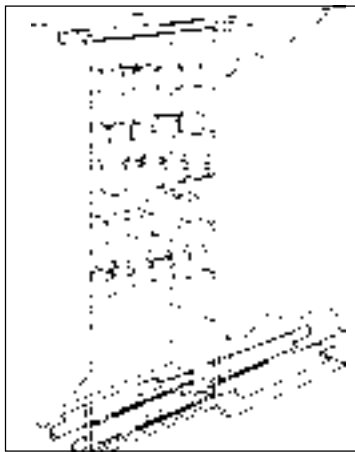

INCHES  
[mm]

- Finish** Bright electro-zinc (C) or black zinc\* (CB) plating
- Length** 12" to 28" [305mm to 711 mm]
- Height** 1.54" [39.1mm]
- Side Space** .75" [19.1mm] slide only  
2.25" [57.2mm] with brackets
- Load** 130 lbs. [59 kg.] per pair\*\*
- Travel** Slide length plus .83" [21.1mm]
- Mounting** Bracket/undermount
- Hardware** #8 pan head or round head screws
- Features** Hold-in detent, silenced open and closed, slide is handed

Part Number	Slide Length	Slide Travel	A	B	C
301-2590-12	12.00 [305]	12.83 [325.9]	4.00 [101.6]	6.00 [152.4]	10.00 [254.0]
301-2590-14	14.00 [356]	14.83 [376.7]	4.00 [101.6]	8.00 [203.2]	12.00 [304.8]
301-2590-16	16.00 [406]	16.83 [427.5]	4.00 [101.6]	10.00 [254.0]	14.00 [355.6]
301-2590-18	18.00 [457]	18.83 [478.3]	4.00 [101.6]	12.00 [304.8]	16.00 [406.4]
301-2590-20	20.00 [508]	20.83 [529.1]	7.00 [177.8]	11.00 [279.4]	18.00 [457.2]
301-2590-22	22.00 [559]	22.83 [579.9]	7.00 [177.8]	13.00 [330.2]	20.00 [508.0]
301-2590-24	24.00 [610]	24.83 [630.7]	7.00 [177.8]	15.00 [381.0]	22.00 [558.8]
301-2590-26	26.00 [660]	26.83 [681.5]	7.00 [177.8]	17.00 [431.8]	24.00 [609.6]
301-2590-28	28.00 [711]	28.83 [732.3]	7.00 [177.8]	19.00 [482.6]	26.00 [660.4]

RTD1000084AA

\* Minimum order quantities may apply.  
 \*\* Load rating based on an 18" slide on a 16" wide shelf cycled 50,000 times.

## Installation Instructions

1. Mark a line at least 1/4" [6.4mm] in from the right side of the cabinet opening and parallel to the cabinet side.
2. Locate a point on this line 1.00" [25.4mm] back from the desired front of the slide.
3. Using #8 pan or round head screws, mount the cabinet member bracket through the first hole at this point.

**NOTE: For maximum strength, ensure that the hold-in detent spring is installed inside the cabinet.**

4. Mount the left hand slide similarly, locating the screw centerline of the cabinet member bracket at least 1/4" [6.4mm] in from the left side of the opening.
5. Keeping the right and left hand slides parallel, install the remainder of the cabinet member screws.

**NOTE: When using soft materials such as particle board, replace rear cabinet mounting screws with through bolts.**

6. With slides extended, center the shelf and drive the screws up through the moving member brackets into the bottom of the shelf.

**NOTE: If the unit is mounted too close to the floor, reverse the procedure above and install the moving member screws first.**

## Slide Ordering Instructions

Complete your slide order for Accuride model 301-2590 by specifying the following:

Total Required Slides \_\_\_\_\_ 20 Pair \_\_\_\_\_ C 301-2590 -16 D  
Slide Finish \_\_\_\_\_  
Slide Model Number \_\_\_\_\_  
Slide Length \_\_\_\_\_  
Optional Polybag Packaging \_\_\_\_\_

## Packaging

**Distributor (D) Pack:** All lengths are packaged 5 pair per box. Polybag includes one pair of slides and mounting screws.

**Bulk (P) Pack:** Slides only. Left hand slides and right hand slides are packaged in separate boxes.

Lengths 12" - 18"      20 each per box  
Lengths 20" - 28"      10 each per box

## Specifications

Slide members and ball retainers: Cold rolled steel  
Ball bearings: Carburized steel

**Note:** Specifications, materials, prices, terms, and delivery are subject to change without notice.

# Accuride

ACCURIDE INTERNATIONAL INC.

12311 Shoemaker Avenue  
Santa Fe Springs, CA 90670

TEL (562) 903-0200

FAX (562) 903-0208

www.accuride.com

Manufacturing, Engineering, and Sales

United States • Germany • Japan • Mexico • United Kingdom



**APPLICATIONS:** For use in wood pedestals, dresser and desk drawers, casework, residential and kitchen cabinetry. **Not intended for lateral file drawer applications. Use for side mount only. This product is covered by U.S. (5,980,007), (488,712) and various foreign patents issued and/or pending.**

Vertical Drawer Adjustment Cam  
32mm System Box Drawer Slide  
Up To 100 lb. [45.5] Capacity

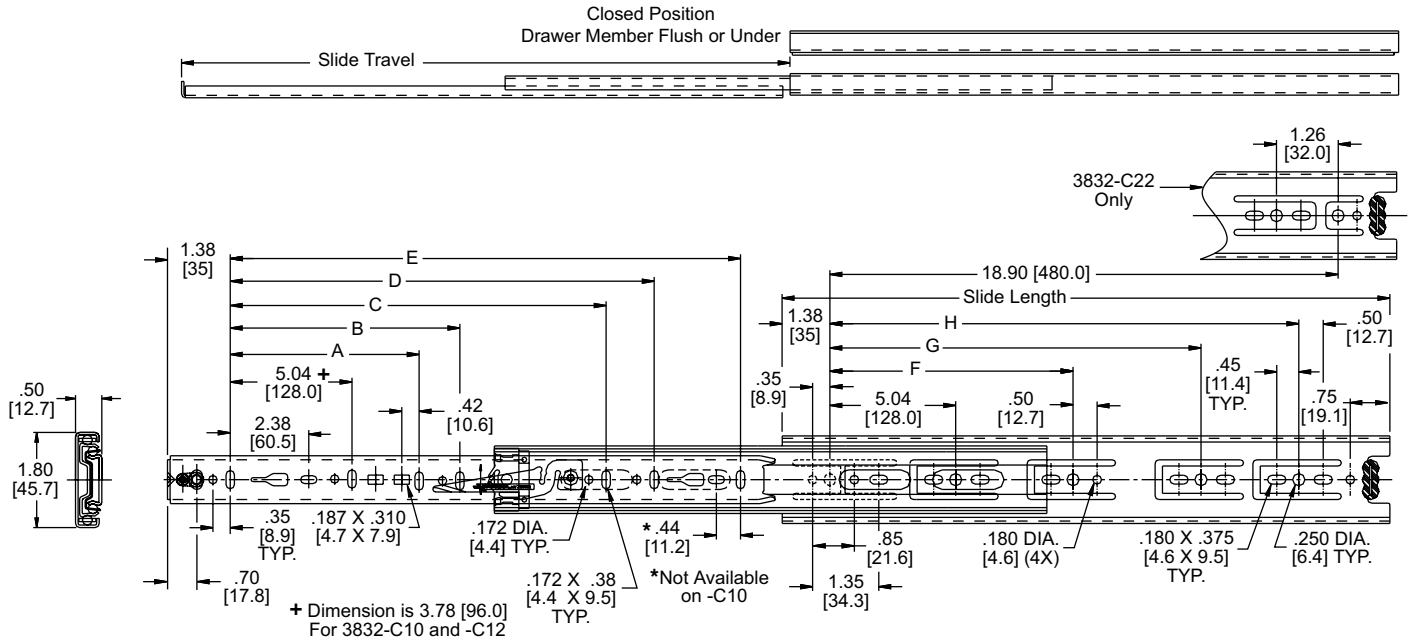

**Finish** 3832C: Bright electro-zinc (C), black zinc (CB), white electrocoating (EW)• , H-coat (CH) 3832 only•

3834C: Bright electro-zinc (C), black zinc (CB),

**Length** 3832C: 10" - 28" [250mm - 700mm]  
3834C: 12" - 28" [300mm - 700mm]

**Travel** 3832C: Full extension  
3834C: 1" Over travel

**Height** 1.80" [45.7mm]

**Load** 3832C: 100 lbs. [45.5kg.]  
3834C: 90 lbs. [41.0 kg.]

**Side Space** .50" +0.062 / -0.0  
[12.7mm +1.6 / -0.0]

**Disconnect** Front, handed lever

**Mounting** Side, optional face frame brackets

**Hardware** Flat head 6mm Euro System screw or #8 pan head screw, Stainless steel screws for (CH) finish only.

**Ball Bearings** C & CB finish: Steel  
EW finish: Acetal polymer in drawer member  
CH finish: Stainless steel

**Features** Drawer member cam action vertical adjustment, hold-in detent; silenced open and closed; 32mm spacing on cabinet member holes

**Optional Weather-Resistant Finish (CH) 3832 only** Electro-zinc plating with H-coat overcoat provides 8 times more protection for installations subjected to indirect weather conditions. Also features stainless steel ball retainer and rivets.

Part Number	Slide Length	Slide Travel 3832	Slide Travel 3834	A	B	C	D	E	F	G	H
3832-C10	9.84 [250]	9.57 [243]						7.56 [192]			
3832-C12	11.81 [300]	12.00 [305]	13.00 [330]					9.52 [242]	8.82 [224]		
3832-C14	13.78 [350]	14.00 [356]	15.00 [381]					11.50 [292]	8.82 [224]		
3832-C16	15.75 [400]	16.00 [406]	17.00 [432]					13.47 [342]	8.82 [224]	12.60 [320]	
3832-C18	17.72 [450]	18.00 [457]	19.00 [483]			12.60 [320]		15.43 [392]	8.82 [224]	13.86 [352]	
3832-C20	19.69 [500]	20.00 [508]	21.00 [533]			12.60 [320]		17.40 [442]	8.82 [224]	16.38 [416]	
3832-C22	21.65 [550]	22.00 [559]	23.00 [584]			‡12.60 [320]	16.38 [416]	19.37 [492]	8.82 [224]	13.86 [352]	17.64 [448]
3832-C24	23.62 [600]	24.00 [610]	25.00 [635]	8.82 [224]		16.38 [416]		21.34 [542]	8.82 [224]	13.86 [352]	18.90 [480]
3832-C26	25.59 [650]	26.00 [660]	27.00 [686]	8.82 [224]		16.38 [416]	21.42 [544]	23.31 [592]	8.82 [224]	13.86 [352]	21.42 [544]
3832-C28	27.56 [700]	28.00 [711]	29.00 [737]	8.82 [224]	11.34 [288]	16.38 [416]	21.42 [544]	25.28 [642]	8.82 [224]	13.86 [352]	21.42 [544]

♦ A lateral file drawer is wider than it is deep.

• Minimum order quantities may apply.

‡ Not available on 3834-22.

† Load rating based on 18" slides mounted in a 16" wide drawer cycled 50,000 times.

**Install Cabinet Member**

1. Separate slide members by simultaneously lifting up the left hand disconnect lever and pushing down the right hand lever.
2. Install cabinet (large) member first. For applications with an overlay drawer front, refer to Figure 1 for conventional mounting and Figure 2 for 32mm System mounting. For applications with an inset drawer front, set the slide back the thickness of the drawer front plus 1/8" [3.2mm].

**Install Drawer Member**

3. Install the drawer member with a screw through the cam adjuster and through a hole or slot at the rear.

**NOTE:**  
Cam **must** install on same center line as drawer member.

Cam Adjuster      Rear Mounting Slot

**NOTE:**  
The cam is designed for use with the standard Accuride truss head screw. If using other screw, ensure screw head height does not exceed 1/16" [1.6mm] since it may cause interference.

1/16" [1.6mm] Maximum Head Height  
Accuride part number 2410-3218-CE

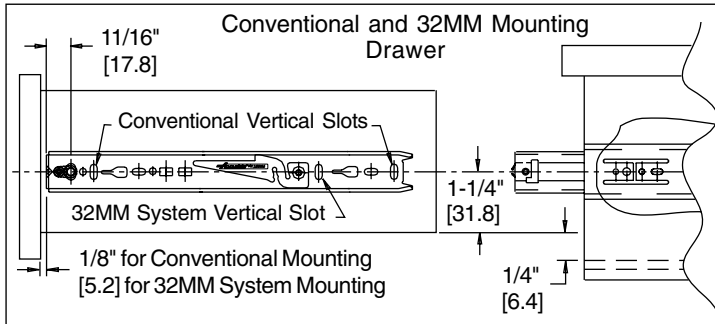
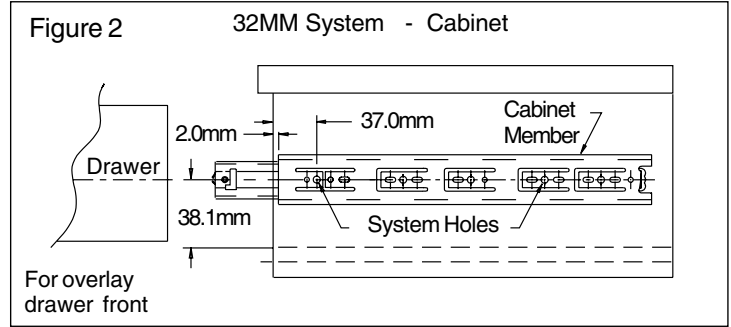
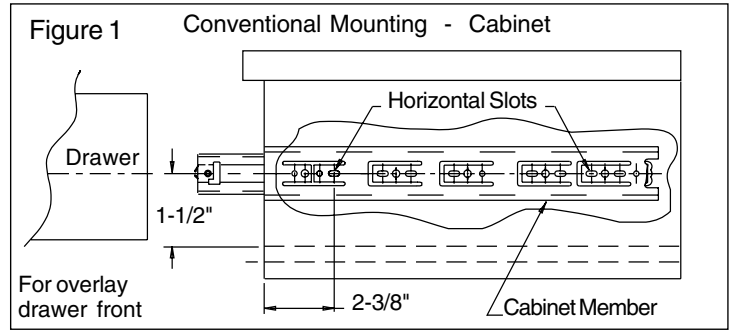

4. Make sure the ball bearing retainers in the cabinet side are fully forward. Install drawer into cabinet. Close the drawer.
5. Open the drawer and rotate the cam with a Phillips or Pozi screwdriver to vertically position the drawer in relation to the cabinet.

**NOTE:**  
Total vertical adjustment is 1/8" [3.2mm] ±1/16" [1.6mm] from center, up and down.

Rotate Cam Up or Down

6. Install additional set screws to secure.
- NOTE:** Install drawer pulls or knobs **after** set screws are in place.

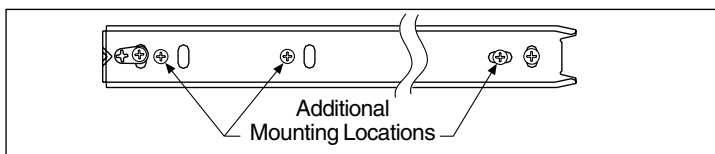

**Optional Face Frame Brackets**

Face frame brackets are ordered as a **kit** or in **bulk**. Brackets are available in clear zinc finish only. Mounting screws are not included.

To order **kits**, specify part number 4180-0322-XE. Each kit contains: 2 front brackets, 2 rear brackets, and installation instructions. Order 1 kit per pair of slides.

For **bulk**, order 2 front brackets (P/N 4010-0516-CE) and 2 rear brackets (P/N 4080-0508-CE) per pair of slides.

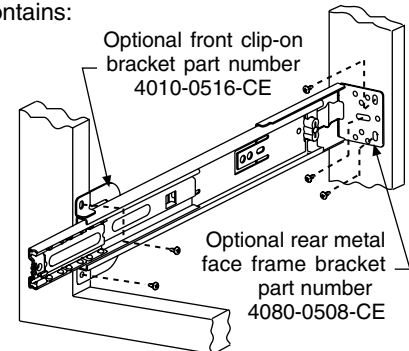

**Packaging Options**

**Models 3832C, 3834C available in D-pack or bulk packaging. Model CH3832 available in D-pack only.**

**Distributor (D) Pack:** All lengths are packaged 10 pair per box. Polybag includes one pair of slides with mounting screws.

**Bulk (P) Pack:** All lengths are packaged 10 pair per box. Slides and screws are ordered and packaged separately.

**Specifications**

Slide members and ball retainers: Cold rolled steel  
Ball bearings: Carburized steel / acetal polymer  
**NOTE:** Specifications, materials, prices, terms, and delivery are subject to change without notice.

**Slide Ordering Instructions**

Complete your slide order for Accuride models 3832C or 3834C by specifying the following:

10 Pair      C 3832      -C18      D

Total Required Slides \_\_\_\_\_

Slide Finish \_\_\_\_\_

Slide Model \_\_\_\_\_

Slide Length \_\_\_\_\_

Polybag Packaging \_\_\_\_\_



ACCURIDE INTERNATIONAL INC.

12311 Shoemaker Avenue  
Santa Fe Springs, CA 90670  
TEL (562) 903-0200  
FAX (562) 903-0208  
www accuride.com

Manufacturing, Engineering, and Sales  
United States • Germany • Japan • Mexico • United Kingdom