

Note: Rockler may not carry all products and/or sizes listed on the Accuride product datasheet



(24626, 29880, 29583, 29503, 24973) **Model 3132SC Self-Close**
 (24999, 20505, 26480, 21497, 27879) **Model 3132EC Easy-Close**

APPLICATIONS: For use in furniture, kitchen and residential cabinetry, and commercial millwork. Meets requirements for BHMA Grade 1 HD-100 standard.
This product is covered by U.S. and various foreign patents issued and/or pending.

Full extension undermount slide
 100 lb. [45.5 kg.] Load Capacity
 Face Frame and 32mm System Compatible

Lengths	Even lengths 12" - 24" [304mm - 610mm]	Mounting	Side, optional hardware kits for face frame and bottom mount brackets, drill jig also available.
Height	1.05" [26.8mm] - Under drawer 1.87" [47.5mm] - Overall	Features	Compatible with 1/2" [12.7] and 5/8" [15.9] drawer box thickness, 1/8" [3.2] range of horizontal and vertical drawer front adjustment.
Travel	Full extension		
Slide Finish	Bright electro-zinc (C)		
Load Rating	100 lbs. * [45.5 kg.]		

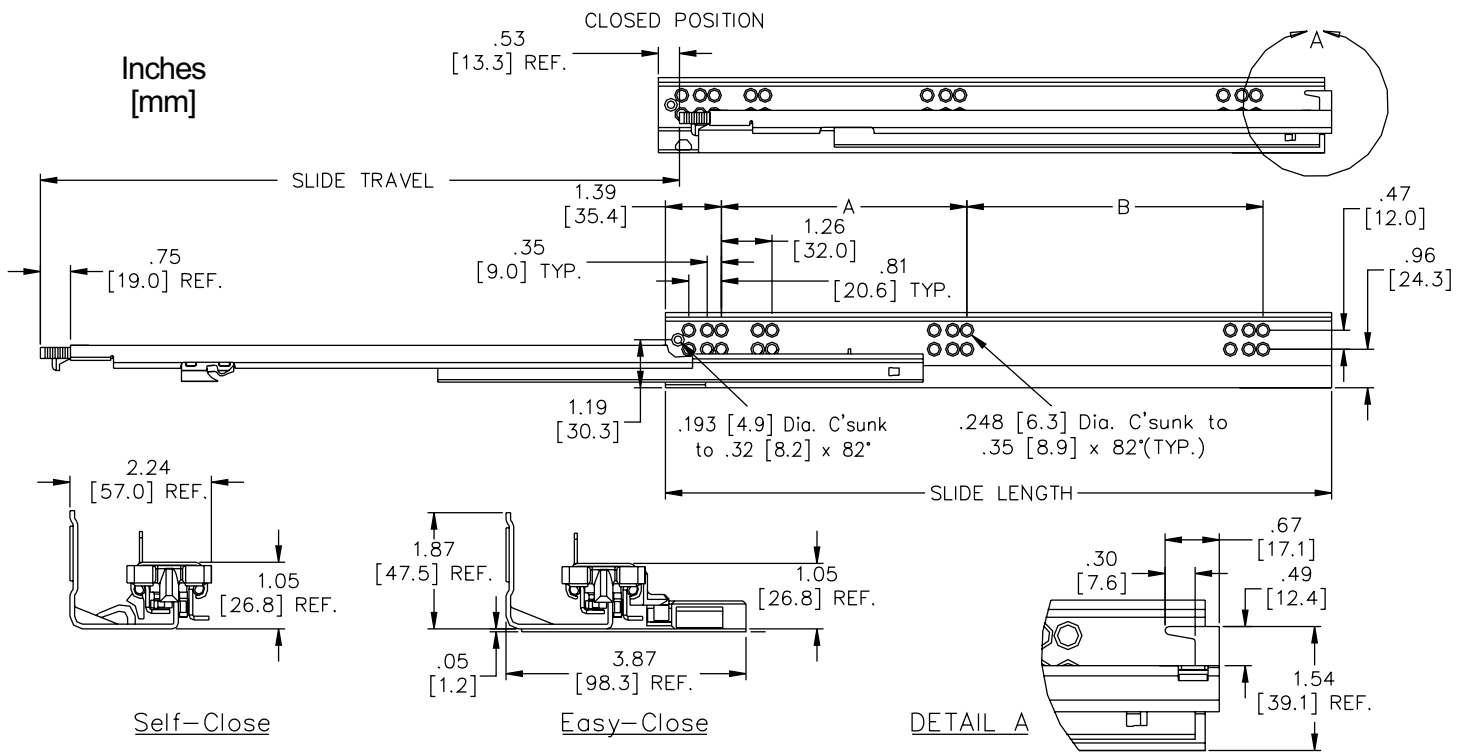

Part Number	Slide Length	Slide Travel	A	B	Drawer Depth	Cabinet Depths
C 3132-12SC-L/R C 3132-12EC-L/R	12.00 [304.8]	11.50 [292.1]	5.04 [128.0]	3.78 [96.0]	12.00 [304.8]	12.63 to 14.63 [320.8] to [371.6]
C 3132-14SC-L/R C 3132-14EC-L/R	14.00 [355.6]	13.50 [342.9]	5.04 [128.0]	3.78 [96.0]	14.00 [355.6]	14.63 to 16.63 [371.6] to [422.4]
C 3132-16SC-L/R C 3132-16EC-L/R	16.00 [406.4]	15.50 [393.7]	5.04 [128.0]	7.56 [192.0]	16.00 [406.4]	16.63 to 18.63 [422.4] to [473.2]
C 3132-18SC-L/R C 3132-18EC-L/R	18.00 [457.2]	17.50 [444.5]	5.04 [128.0]	7.56 [192.0]	18.00 [457.2]	18.63 to 20.63 [473.2] to [524.0]
C 3132-20SC-L/R C 3132-20EC-L/R	20.00 [508.0]	19.50 [495.3]	8.82 [224.0]	7.56 [192.0]	20.00 [508.0]	20.63 to 22.63 [524.0] to [574.8]
C 3132-22SC-L/R C 3132-22EC-L/R	22.00 [558.8]	21.50 [546.1]	8.82 [224.0]	10.08 [256.0]	22.00 [558.8]	22.63 to 24.63 [574.8] to [625.6]
C 3132-24SC-L/R C 3132-24EC-L/R	24.00 [609.6]	23.50 [596.9]	8.82 [224.0]	10.08 [256.0]	24.00 [609.6]	24.63 to 26.63 [625.6] to [676.4]

* Load rating based on 18" slides installed in a 24" wide drawer cycled 50,000 times. RTD10000169AB

Drawer and Cabinet Build Requirements

FIGURE 1

Build drawer and cabinet based on dimensions shown. Inside drawer width must equal inside cabinet width minus 1-3/4" [44.5].

Maximum drawer height equals cabinet opening height minus 13/16" [20.6].

Maximum outside drawer width equals inside cabinet width minus .50" [12.7], based on 5/8" [15.9] thick drawer.

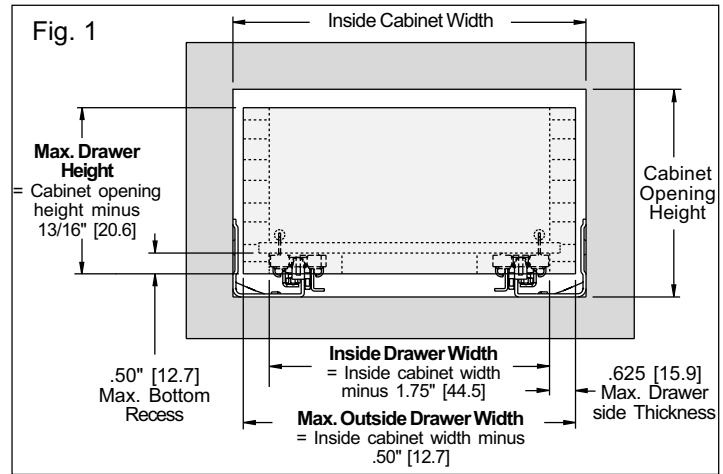

FIGURE 2

Drawer length equals slide length.

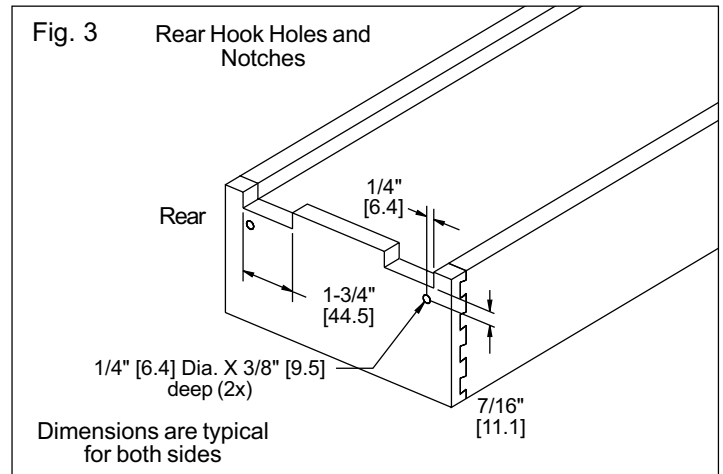
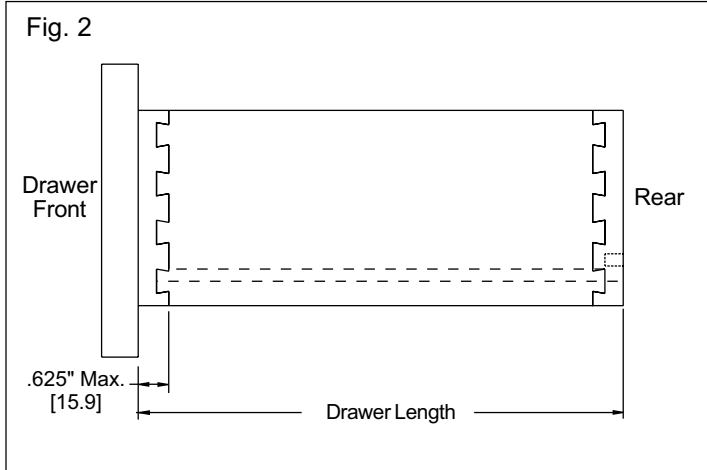

FIGURE 4

Pre-drill four holes for disconnect handle assemblies at 10° angle from bottom panel. ‡

Drawer Preparation

FIGURE 3

Notch drawer back flush with drawer bottom to provide clearance for slides. ‡

Pre-drill two holes for slide hooks. ‡

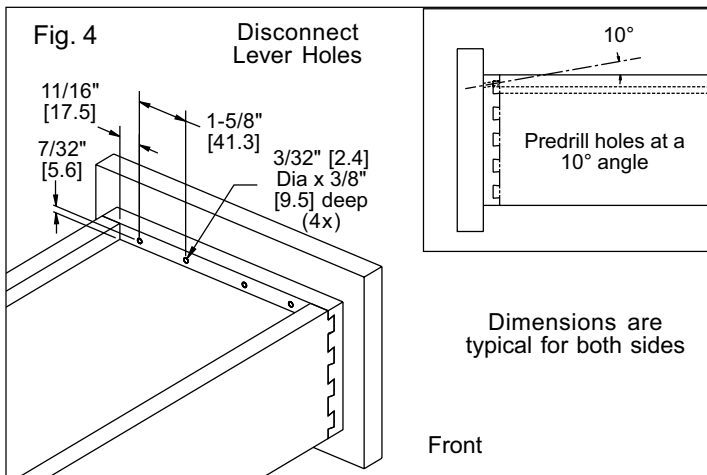

FIGURE 5

Install both disconnect handles to bottom of the drawer. **NOTE:** The levers should curve toward the center of the drawer.

Place disconnect handles against each inside corner of the drawer bottom and install with #6 pan head screws.

Alternative Lever Mounting (Vertical)

FIGURE 5a

For drawers with bottom panels flush to the drawer sub-front, an optional vertical mount disconnect lever is available. Order the slides in bulk packaging and order the vertical mount disconnect levers separately. See ordering information for details.

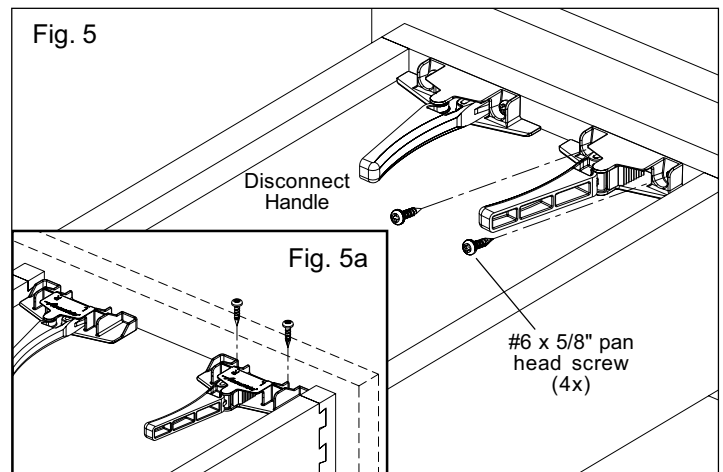

‡ **NOTE:** An optional drill jig can be used to mark the notch and pre-drill holes on the drawer.

Cabinet Member Installation

Overlay Side-mount or Frameless

FIGURE 6

If needed, pre-drill a hole 37mm from cabinet front. The optional drill jig can be used to pre-drill this hole and/or pencil mark line in the 37mm location from the cabinet front. For location of additional screw holes refer to the tabulated data on front page.

Install slides to cabinet wall with #8 x 5/8" flat head screws. Align slide member hole shown to pre-drilled hole 37mm from front of cabinet to ensure proper gap. A minimum of 3 screws are recommended for each side.

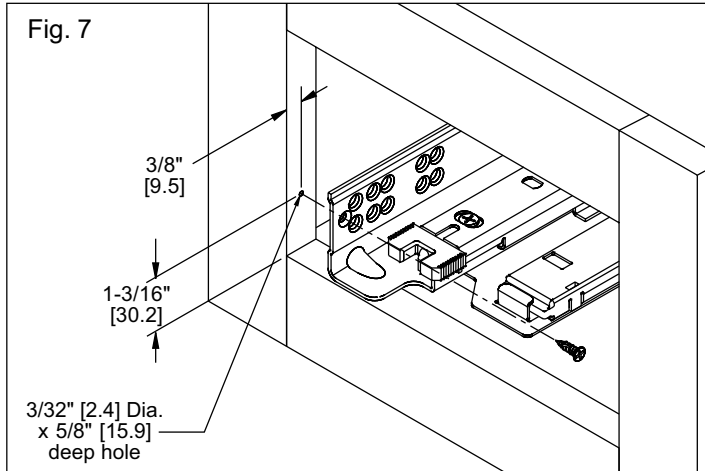
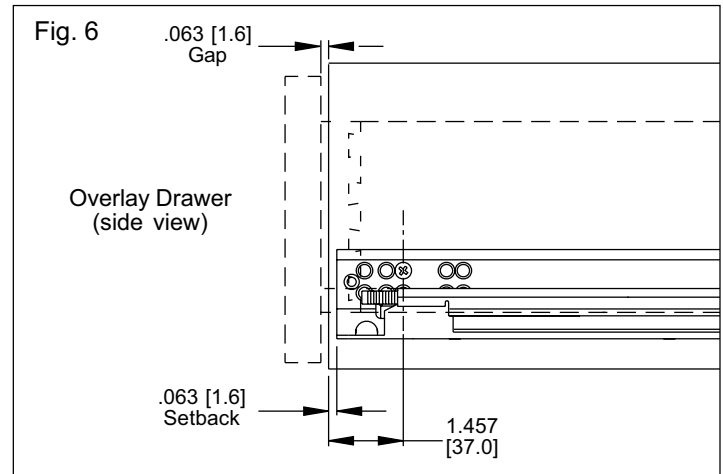

FIGURE 8

Assemble the face frame bracket to rear slot of the slide.

Install front of slide to face frame hole with # 8 x 5/8 flat head screw (see figure 7).

Install #8 X 5/8" pan head screw through the plastic adjuster on the face frame bracket to the back of the cabinet (screw hole location is shown in figure 8A). The adjuster clip will lightly hold the bracket in place to allow further adjustments after the drawer is installed.

Overlay Face Frame

FIGURE 7

Pre-drill the front face frame hole as shown. The optional drill jig can be used to pre-drill this hole.

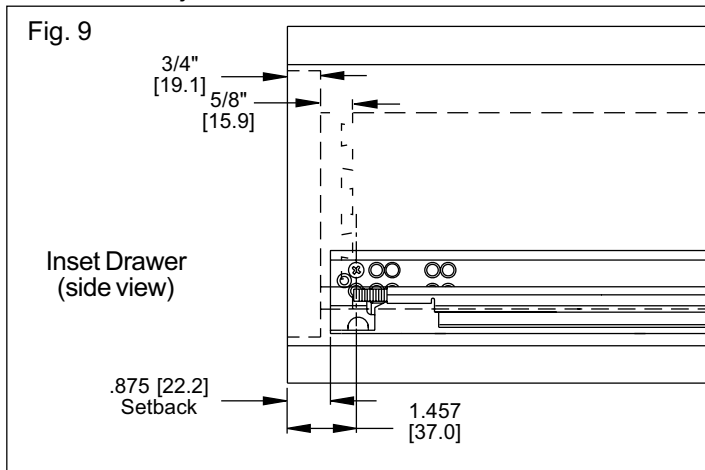
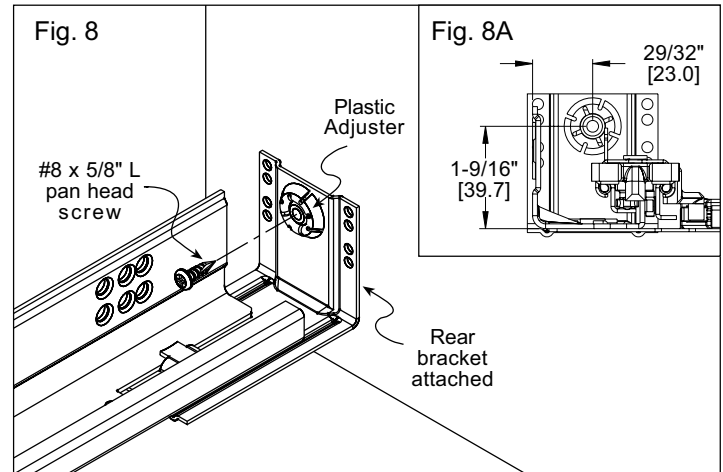

Inset Drawer

FIGURE 9

Align slide member hole to predrilled hole 37mm from front of cabinet for 5/8" drawer box thickness. Install slides to cabinet wall with #8 x 5/8" flat head screws.

Bottom Mount

FIGURE 10

Install mounting bracket to bottom of the cabinet. Use #8-32 flat head self-tapping screws to mount slide to the bracket.

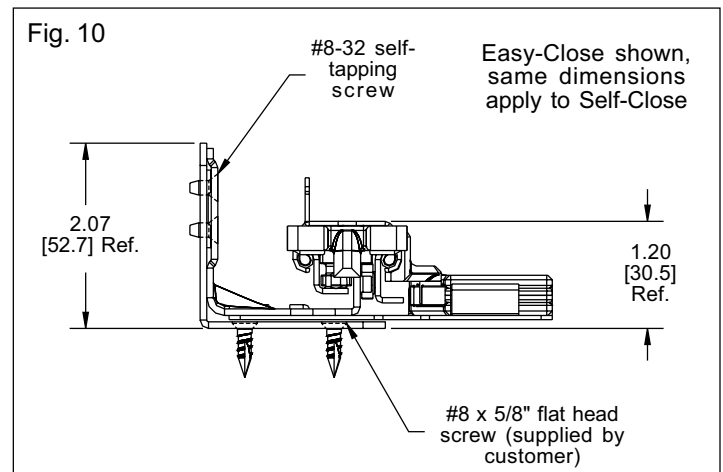

Installation and Adjustment Instructions

Drawer Installation and Adjustments

FIGURE 11

Connect the drawer to the slides. Lower the drawer onto the slides and push until the handles lock onto the front of the slides. Continue to push until the drawer "ratchets" into the desired depth. Check to ensure the rear hooks on the slide fit into the rear holes of the drawer.

For face frame mounting, pull drawer to the extended position. Adjust the rear bracket vertically and horizontally to ensure the mounted drawer is square to the cabinet and the slides are parallel to each other. Secure the rear bracket to the cabinet rear wall with additional #8 x 5/8" pan head screws.

FIGURE 12

Adjust horizontal and vertical position of drawer front by rotating the corresponding cam with a #2 phillips or #2 pozi screwdriver.

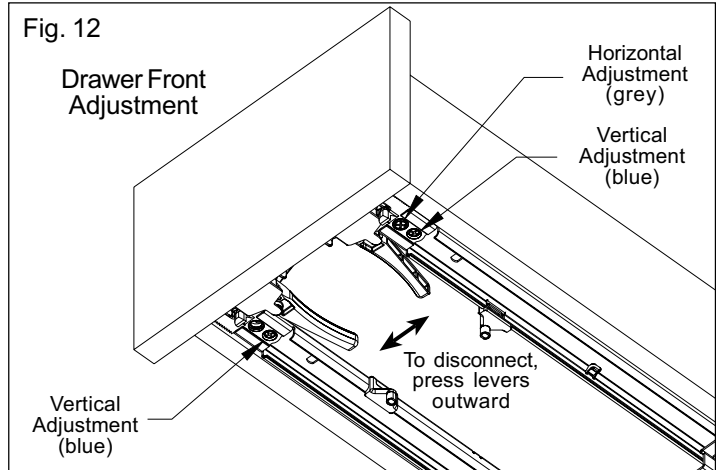
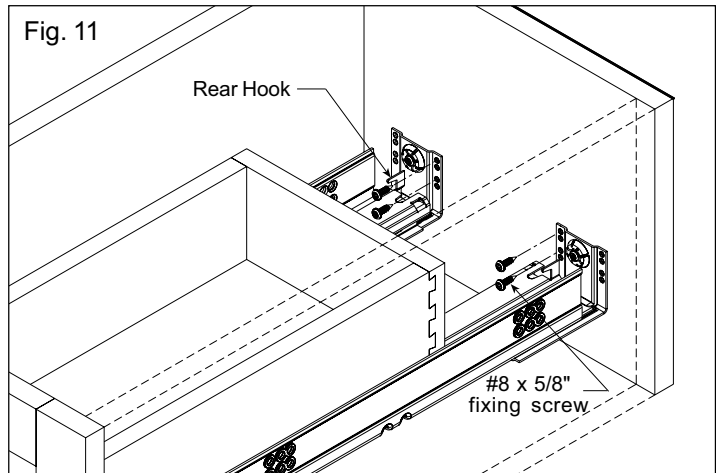

Ordering Instructions

Complete your order for Accuride model 3132 by specifying the following:

Model 3132 Self-Close	100 Pair	C	3132	-18	SC	D
Total Required Slides	_____	_____	_____	_____	_____	_____
Slide Finish	_____	_____	_____	_____	_____	_____
Model Number	_____	_____	_____	_____	_____	_____
Slide Length	_____	_____	_____	_____	_____	_____
Self-Close Feature	_____	_____	_____	_____	_____	_____
Single Pair Packaging	_____	_____	_____	_____	_____	_____
Model 3132 Easy-Close	100 Pair	C	3132	-18	EC	D
Total Required Slides	_____	_____	_____	_____	_____	_____
Slide Finish	_____	_____	_____	_____	_____	_____
Model Number	_____	_____	_____	_____	_____	_____
Slide Length	_____	_____	_____	_____	_____	_____
Easy-Close Feature	_____	_____	_____	_____	_____	_____
Single Pair Packaging	_____	_____	_____	_____	_____	_____

Hardware Kits

Optional Face Frame Brackets

Face frame brackets are ordered as a kit, or in bulk. To order the kit, specify part number 4180-0560-XE. Each kit contains 2 rear brackets, mounting hardware and one installation sheet.

Optional Bottom Mount Brackets

Bottom mount brackets are ordered as a kit, or in bulk. Mounting screws are not included. To order the kit, specify part number 4180-0569-XE. Each kit contains 4 bottom mount brackets, self-tapping screws and one installation sheet.

Optional Drill Jig (P/N 4180-0568-XE)

The jig provides hole locations for drawer hook, front face frame hole, disconnect lever and front cabinet holes.

Packaging Options

Distributor (D) Pack

All lengths are packaged one pair per box. Box includes one pair of slides with 6 ea. #8 x 5/8" phillips flat head screws (for slides), 2 ea. standard horizontal disconnect levers and 4 ea. #6 x 5/8" phillips pan head screws (for levers).

Bulk (P) Pack

All lengths are packaged 6 pair per box. A separate polybag containing 36 ea. #8 x 5/8" phillips flat head screws are included. Disconnect levers and screws for lever installation are ordered separately.

Disconnect Lever Packaging Options

Optional Vertical Mount (P/N 4180-0584-XE)

One pair individually packaged with 4 ea. #6 x 5/8" phillips pan head type 17s in a polybag. 60 kits per box.

Standard Horizontal Mount, Individual (P/N 4180-0559-XE)

One pair individually packaged with 4 ea. #6 x 5/8" phillips pan head type 17s in a polybag. 60 kits per box.

Standard Horizontal Mount, Bulk (P/N 4180-0587-XE)

Left hand and right hand levers are packaged separately. 60 levers per box. Each box contains 120 mounting screws in a polybag.

Specifications

Slide members:	Cold rolled steel
Ball retainers:	Polymer
Ball bearings:	Carburized steel and polymer
Rollers:	Polymer

Note: Specifications, materials, prices, terms, and delivery are subject to change without notice.

Accuride

ACCURIDE INTERNATIONAL INC.

12311 Shoemaker Avenue
Santa Fe Springs, CA 90670

TEL (562) 903-0200

FAX (562) 903-0208

www accuride.com

Manufacturing, Engineering, and Sales
United States • Germany • Japan • Mexico • United Kingdom