

INSTALLATION INSTRUCTIONS

6000 SERIES FULL CIRCLE REV-A-SHELF SYSTEM WITH TELESCOPING PIVOT HARDWARE

(82785)

1. Locate the bottom pivot by placing one of the shelves on the base of the cabinet and marking through the center hole making sure the shelf will have at least 3/8 in. side clearance all around.
2. Pilot drill (1/8 in. dia.) holes and fasten the bottom pivot with four (4) 1/2 in. x 8 truss head wood screws.
3. Slide the collar assembly over the center shaft and start the screw into the hole in the center shaft.
4. Insert the upper shaft assembly all the way into the center shaft.
5. Set the shaft assembly on the bottom pivot and extend the upper shaft to the top of the cabinet. Plumb with level to locate the center for the top pivot bracket. Pilot drill (1/8 in. dia.) holes and fasten the top pivot with four (4) 1/2 in. x 8 truss head wood screws.
6. You are now ready to assemble the unit inside the cabinet. Place the shelves inside the cabinet over the bottom pivot bracket and slide the shaft assembly through the shelves.
7. Lift the shaft assembly and engage it in the bottom pivot, while holding the shelves up with one hand. Extend the upper shaft assembly and engage it in the top pivot bracket and tighten the locking screw on the collar assembly securely.
8. Adjust the shelves to the desired heights and tighten the shelf locking screws securely.

NOTE: A little lubricant (white grease or equivalent) applied to the top and bottom pivot will insure quiet and smooth turning.

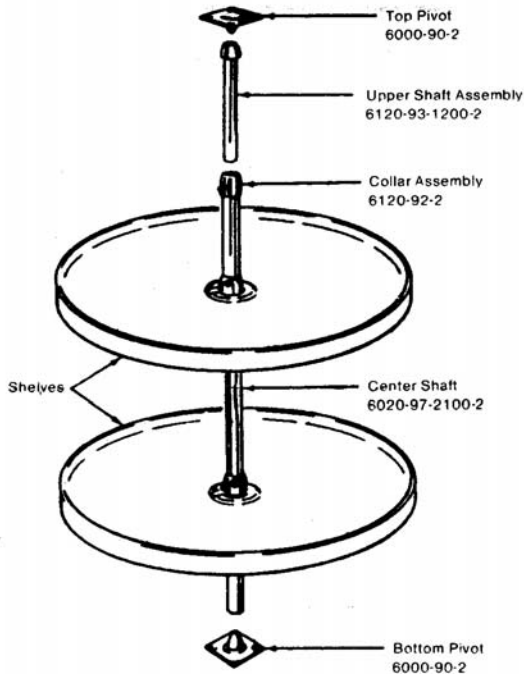

REV-A-SHELF®

P.O. BOX 99585 • JEFFERSONTOWN, KY. 40299
502-499-5835 • FAX 502-491-2215

RTD10000357AA 16000 T