



(82751) 33" & 39" HALF MOON
(82769) (BLIND CORNER)
(87959) INSTRUCTIONS
 (RIGHT SIDE ILLUSTRATION ONLY)

IMPORTANT: Before you begin, familiarize yourself with the kit contents, identify all parts, read through all instruction information and have the necessary tools on hand to get started.

CUSTOMER SERVICE: Toll Free Consumer Help Line for your product questions during the weekday business hours:

800-626-1126

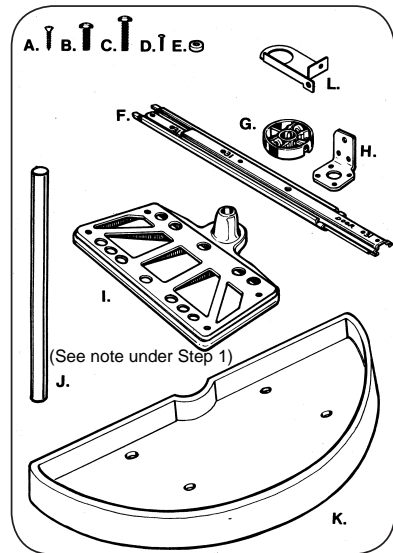

PART IDENTIFICATION

- A. #8 x 3/4" Oval Head Phillips Wood Screw -7 req.
- B. 1/4 - 20 x 3/4" Phillips Machine Screw -4 req.
- C. 1/4 - 20 x 1" Phillips Machine Screw -8 req.
- D. #10 x 1/2" Phillips Machine Screw -4 req.
- E. Plastic Screw Hole Cap -16 req.
- F. Slide Assembly -2 req.
- G. Positioner Base Assembly -2 req.
- H. Support Bracket -1 req.
- I. Half Moon Tray -2 req.
- J. Shaft 17" w/cap -1 req.
- K. Shelf Support -2 req.
- L. Rev-A-Tray Support Bracket -1 req.

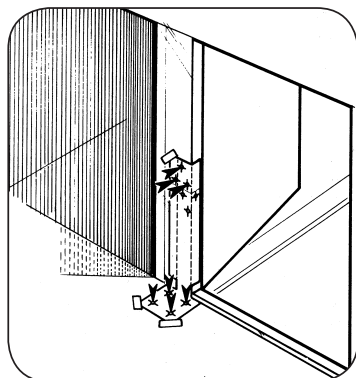

STEP 1

Position and tape template on inside of the face frame vertically (hinge side) as shown in illustration. Using a 1/8" diameter bit, drill 3/8" deep pilot holes through the template at the 7 arrow locations shown.

NOTE: If installing Rev-A-Tray (single tray) note hole locations on template.

Rockler carries single Rev-A-Tray products 82751 and 82769. Hardware kit 87959, which allows two Rev-A-Trays to be stacked, is available separately.

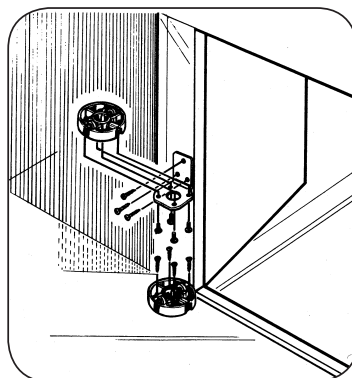

STEP 2

Match positioner base over 4 base holes as shown and install to cabinet bottom using four (4) #8 x 3/4" oval head Phillips wood screws. Match support bracket over 3 remaining pilot holes as shown and install it to cabinet frame using three (3) #8 x 3/4" oval head Phillips wood screws. Now match the other positioner base over the 4 support bracket and attach using four (4) #10 x 1/2" machine screws. **NOTE:** Lock down screw or positioner base assembly toward opening. **NOTE:** For Rev-A-Tray use bracket (L).

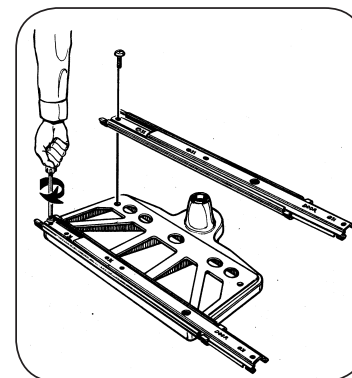

STEP 3

Place slides on top of shelf support with this slide toward door opening. Pull top half of slide all the way out and match bottom half end holes over threaded holes on shelf support. Fasten slides to support using two (2) (1 per slide) 1/4 - 20 x 3/4" Phillips machine screws (see illustration).

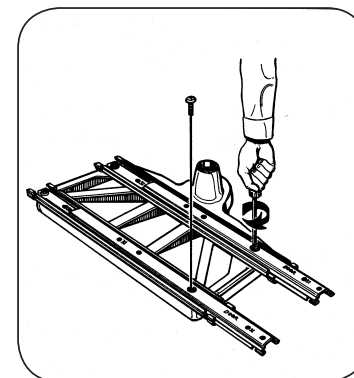

STEP 4

With top half of slides still all the way extended, complete slide installation to 2 remaining threaded holes on shelf support. Use two (2) more (1 per slide) 1/4-20 x 3/4" Phillips machine screws and screw them in through the large access holes in top half of slides (see illustration).

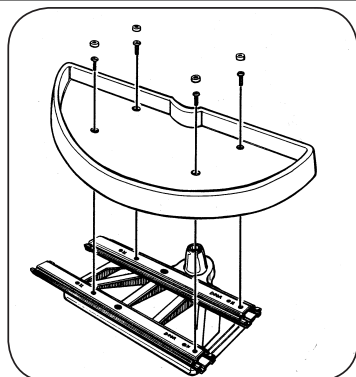

STEP 5

Now match a Half Moon tray over slides and install it to slides with four (4) 1/4 - 20 x 1" Phillips machine screws. Illustration shows the 4 holes for correct installation of tray to slides. Then push (4) plastic screw cover caps into tray holes (caps shown over screws in illustration).

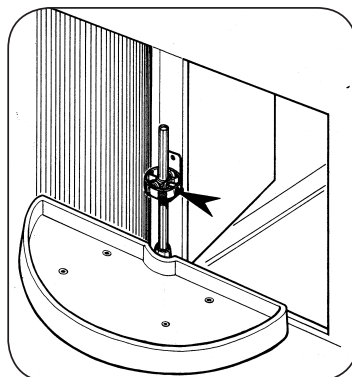

STEP 6

Take your pivot & slide assembly, match it over the bottom positioner base and insert the shaft through the top positioner base, the pivot and slide assembly, and into the bottom positioner base until the shaft bottom (open end) sets on cabinet bottom. Now using your screw driver, tighten the set screws on both positioner bases (arrow points out top set screw). Be sure to tighten bottom positioner base set screw (not visible in illustration).

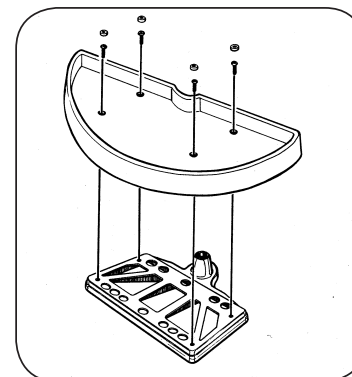

STEP 7

Pivot Only Assembly: Install Half Moon tray directly to shelf support using four (4) 1/4 - 20 x 1" Phillips machine screws. Then push plastic caps into all 4 tray holes (illustration shows plastic caps above screws).

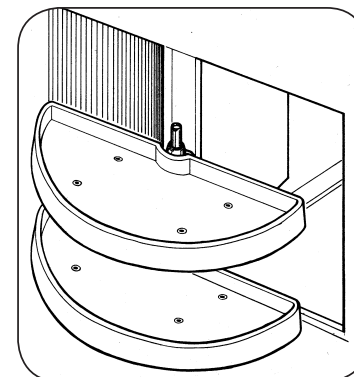

STEP 8

Now slide the pivot assembly on shaft so it rests on the top positioner base. Your installation is now complete and should look like the illustration.



**33" & 39" HALF MOON
(BLIND CORNER)
INSTRUCTIONS
(LEFT SIDE ILLUSTRATION ONLY)**

IMPORTANT: Before you begin, familiarize yourself with the kit contents, identify all parts, read through all instruction information and have the necessary tools on hand to get started.

CUSTOMER SERVICE: Toll Free Consumer Help Line for your product questions during the weekday business hours:

800-626-1126

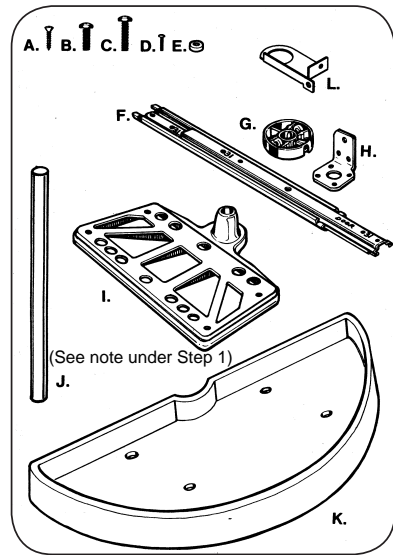

PART IDENTIFICATION

- A. #8 x 3/4" Oval Head Phillips Wood Screw -7 req.
- B. 1/4 - 20 x 3/4" Phillips Machine Screw -4 req.
- C. 1/4 - 20 x 1" Phillips Machine Screw -8 req.
- D. #10 x 1/2" Phillips Machine Screw -4 req.
- E. Plastic Screw Hole Cap -16 req.
- F. Slide Assembly -2 req.
- G. Positioner Base Assembly -2 req.
- H. Support Bracket -1 req.
- I. Half Moon Tray -2 req.
- J. Shaft 17" w/cap -1 req.
- K. Shelf Support -2 req.
- L. Rev-A-Tray Support Bracket -1 req.

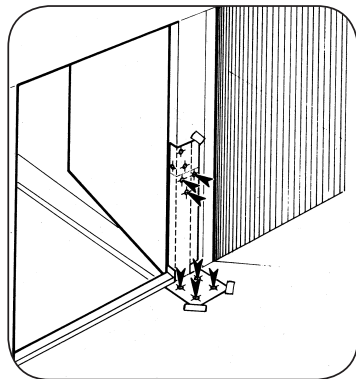

STEP 1

Position and tape template on inside of the face frame vertically (hinge side) as shown in illustration. Using a 1/8" diameter bit, drill 3/8" deep pilot holes through the template at the 7 arrow locations shown.

NOTE: If installing Rev-A-Tray (single tray) note hole locations on template.

Rockler carries single Rev-A-Tray products 82751 and 82769. Hardware kit 87959, which allows two Rev-A-Trays to be stacked, is available separately.

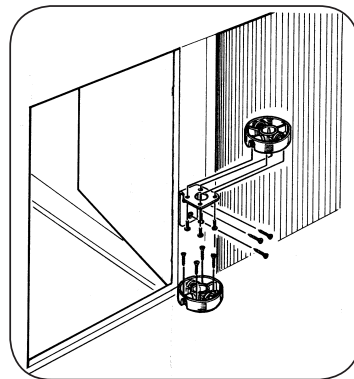

STEP 2

Match positioner base over 4 base holes as shown and install to cabinet bottom using four (4) #8 x 3/4" oval head Phillips wood screws. Match support bracket over 3 remaining pilot holes as shown and install it to cabinet frame using three (3) #8 x 3/4" oval head Phillips wood screws. Now match the other positioner base over the 4 support bracket attach by using four (4) #10 x 1/2" machine screws. **NOTE:** Lock down screw on positioner base assembly toward opening. **NOTE:** For Rev-A-Tray use bracket (L).

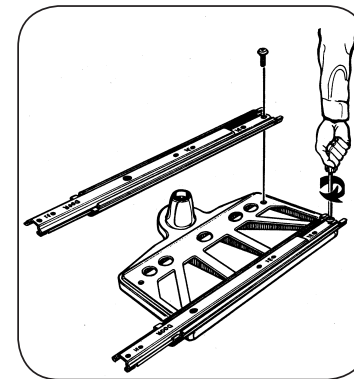

STEP 3

Place slides on top of shelf support with this slide toward door opening. Pull top half of slide all the way out and match bottom half end holes over threaded holes on shelf support. Fasten slides to support using two (2) (1 per slide) 1/4 - 20 x 3/4" Phillips machine screws (see illustration).

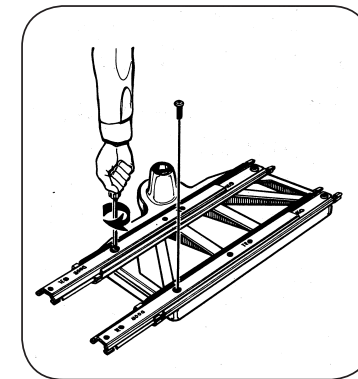

STEP 4

With top half of slides still all the way extended, complete slide installation to 2 remaining threaded holes on shelf support. Use two (2) more (1 per slide) 1/4-20 x 3/4" Phillips machine screws and screw them in through the large access holes in top half of slides (see illustration).

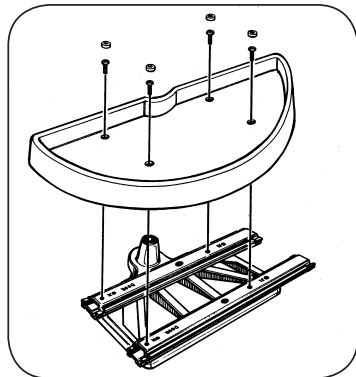

STEP 5

Now match a Half Moon tray over slides and install it to slides with four (4) 1/4 - 20 x 1" Phillips machine screws. Illustration shows the 4 holes for correct installation of tray to slides. Then push 4 plastic screw cover caps into tray holes (caps shown over screws in illustration).

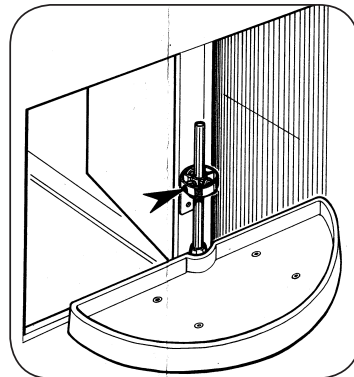

STEP 6

Take your pivot & slide assembly, match it over the bottom positioner base and insert the shaft through the top positioner base, the pivot and slide assembly, and into the bottom positioner base until the shaft bottom (open end) sets on cabinet bottom. Now using your screw driver, tighten the set screws on both positioner bases (arrow points out top set screw). Be sure to tighten bottom positioner base set screw (not visible in illustration).

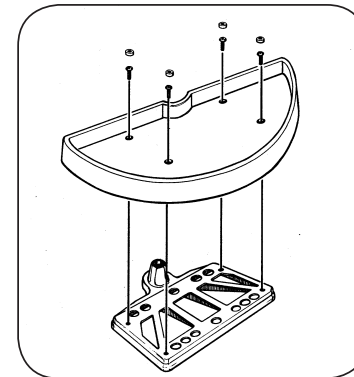

STEP 7

Pivot Only Assembly: Install Half Moon tray directly to shelf support using four (4) 1/4 - 20 x 1" Phillips machine screws. Then push plastic caps into all 4 tray holes (illustration shows plastic caps above screws).

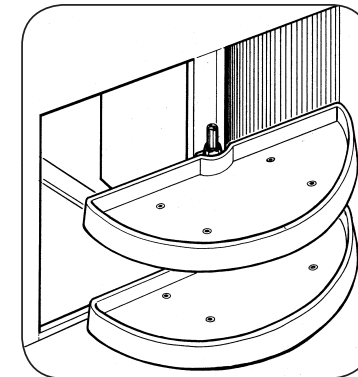

STEP 8

Now slide the pivot assembly on shaft so it rests on the top positioner base. Your installation is now complete and should look like the illustration.

Rev-A-Shelf, L.L.C.

2409 Plantside Dr. • Jeffersonton, KY 40299 • (800) 626-1126 • www.rev-a-shelf.com