

MODEL 1920

AIR LIFT- HEIGHT ADJUSTMENT INSTRUCTIONS

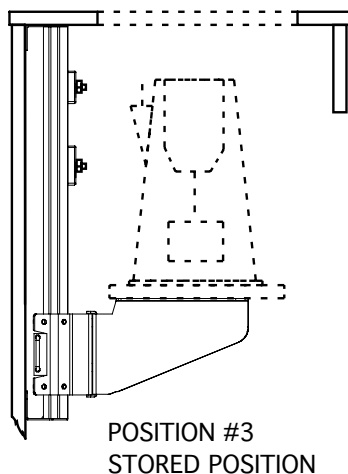
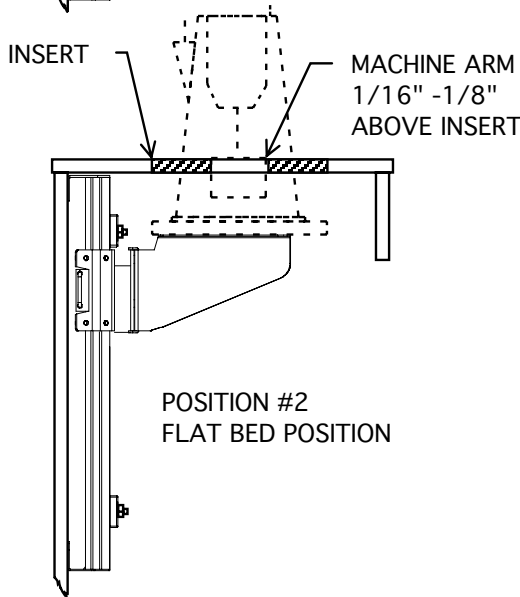
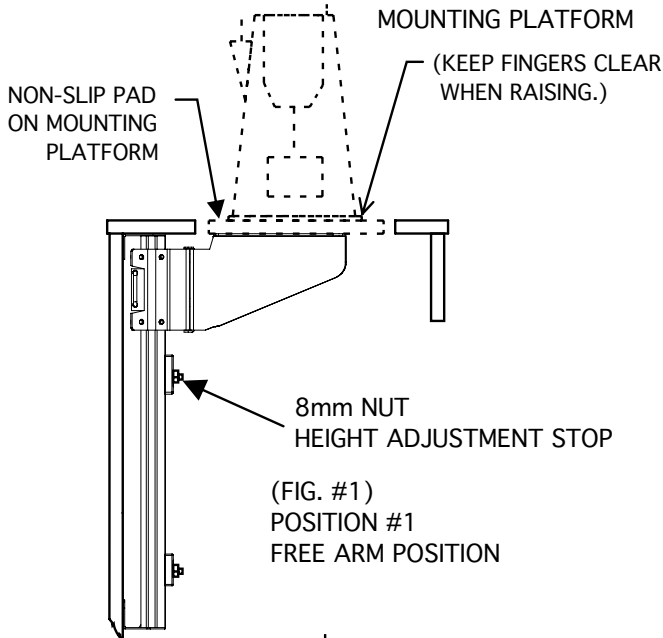

THE NEW AIR LIFT CAN BE ADJUSTED TO FIT MOST FREE ARM MACHINES.

INSTALLING MACHINE TO MOUNTING PLATFORM

1. SET CABINET MOUNTING PLATFORM IN POSITION #2 (FLAT BED POSITION) LAY NON-SLIP PAD ON MOUNTING PLATFORM.

*CAUTION - KEEP FINGERS CLEAR OF OPENING WHEN RAISING PLATFORM.

2. PLACE FREE ARM MACHINE ON PLATFORM AND LOCATE PROPER MOUNTING POSITION USING CORRECT INSERT. (INSERT TO FIT YOUR MACHINE CAN BE PURCHASED AT LOCAL DEALER.)

3. WITH USE OF NON-SLIP PAD BETWEEN MOUNTING PLATFORM AND MACHINE, MOUNTING HARDWARE SHOULD NOT BE REQUIRED.

4. TO ADJUST LEVEL OF MACHINE IN FLAT BED POSITION #2:

- A. NOTE THE DISTANCE NEEDED TO ADJUST AIRLIFT.
- B. MOVE PLATFORM TO POSITION #1.
- C. LOOSEN 2- 8mm NUTS OF HEIGHT ADJUSTMENT STOP (REF. FIG. #1) MOVE UP OR DOWN THE REQUIRED AMOUNT AND RE-TIGHTEN.
- D. RETURN PLATFORM TO POSITION #2 (FLAT BED POSITION). REPLACE INSERT AROUND MACHINE AND CHECK FOR PROPER HEIGHT. ARM OF MACHINE SHOULD BE 1/16" TO 1/8" ABOVE LEVEL ON INSERT.

5. PLACE CONTROL CORD THROUGH CORD HOLE LOCATED ON RIGHT REAR CORNER OF MOUNTING PLATFORM.

MODEL 1920 HORN AIRLIFT OPERATING INSTRUCTIONS

8/16/2006

NOTE: THE TOUCH RELEASE AIRLIFT IS A BREEZE TO OPERATE. (NO MANUAL TRIP-LEVER REQUIRED) BY SIMPLY APPLYING A DOWNWARD PRESSURE THE AIRLIFT WILL STOP AT ONE OF THE THREE PRE-SET POSITIONS (FREE ARM, FLAT BED, AND STORAGE).

PLACE SEWING MACHINE ON MOUNTING PLATFORM.

TO LOWER

- PLACE BOTH HANDS ON THE MACHINE AND, USING YOUR BODY WEIGHT, SIMPLY PUSH THE MACHINE TO EITHER STORAGE OR FLAT-BED POSITION.

TO RAISE

- EXERT A SLIGHT DOWNWARD PRESSURE ON THE MACHINE HEAD TO RELEASE AIRLIFT TO RAISE.

PLEASE NOTE: IT IS VERY DIFFICULT TO ADJUST THE LIFTER TO SUIT VARIOUS WEIGHTS OF SEWING MACHINES. IF YOUR SEWING MACHINE IS LIGHT, THEN YOU WILL REQUIRE A LITTLE MORE EFFORT TO PUSH THE MACHINE TO THE STORAGE POSITION, BUT IT SHOULD COME UP QUITE EASILY. IF IT IS HEAVY, THEN IT WILL BE EASY TO PUSH TO THE STORAGE POSITION, BUT YOU MAY NEED TO ASSIST THE LIFTER TO RAISE THE MACHINE OVER THE LAST INCH OR TWO. **FOR HEAVIER MACHINES THE AIRLIFT IS EQUIPPED WITH A LOCKING MECHANISM TO PREVENT DOWNWARD DRIFTING AT TOP TWO POSITIONS. PLEASE READ BELOW FOR OPERATING INSTRUCTIONS.**

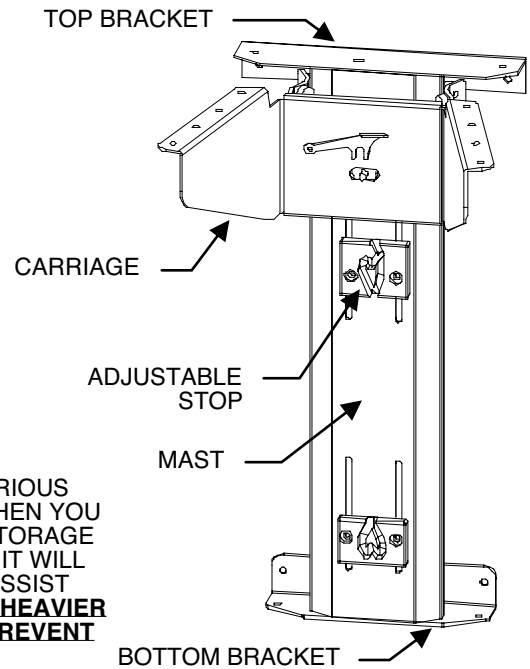

LOCKING MECHANISM OPERATING INSTRUCTIONS

LOCKING MECHANISM

TO LOCK CARRIAGE ON AIRLIFT, SIMPLY ROTATE LOCKING MECHANISM DOWN ONTO METAL PIN AS SHOWN.

TO UNLOCK CARRIAGE ON AIRLIFT, ROTATE LOCKING MECHANISM UP FROM METAL PIN.

