

# Desk Support and Hinge Set

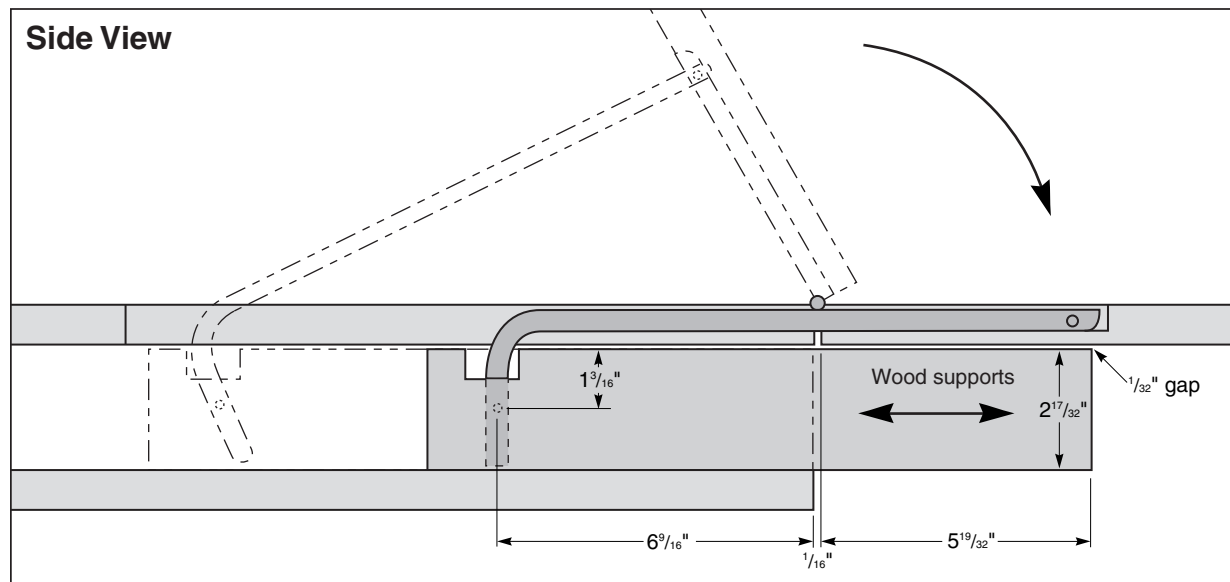

## Installation notes

- Support arm requires a 1/4" slot cut in the desktop along each side.
- Hinges are mortised in to desktop and edges of drop front.
- An optional wood cross member may be used to tie the wood supports to each other.
- 1/32" gaps are recommended between moving parts.

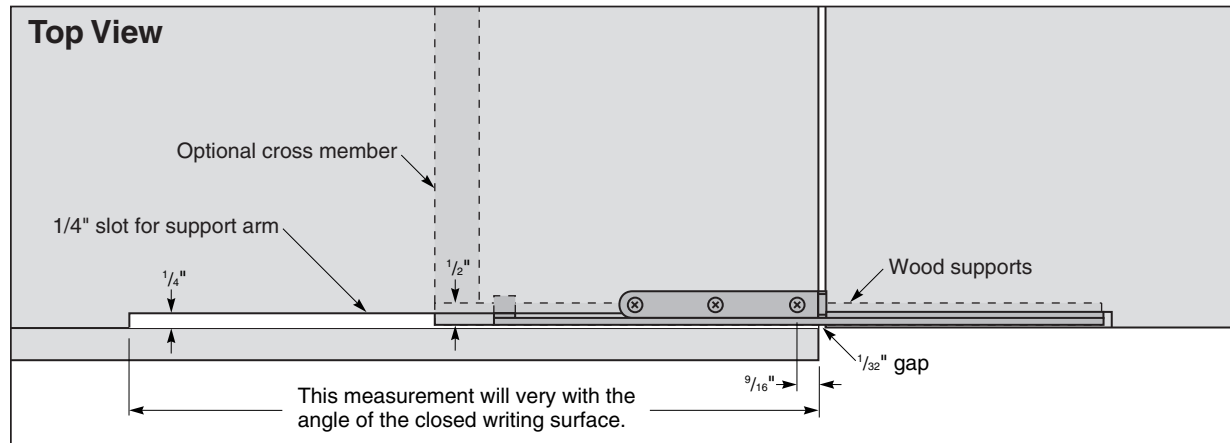